

Silicon PNP Darlington Power Transistors

TIP115/116/117

DESCRIPTION

- With TO-220C package
- DARLINGTON
- High DC current gain
- Low collector saturation voltage
- Complement to type TIP110/111/112

APPLICATIONS

- For industrial use

PINNING

PIN	DESCRIPTION
1	Base
2	Collector;connected to mounting base
3	Emitter

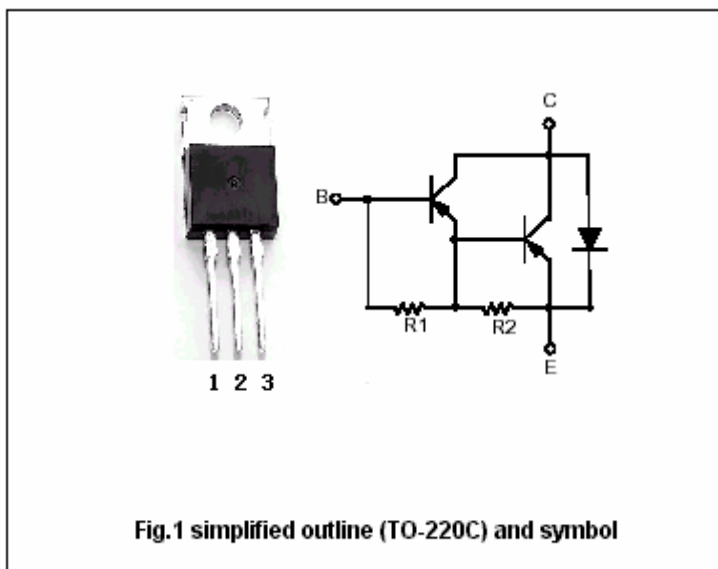

Fig.1 simplified outline (TO-220C) and symbol

Absolute maximum ratings(Tc=25 )

SYMBOL	PARAMETER	CONDITIONS	VALUE	UNIT
V <sub>CBO</sub>	Collector-base voltage	TIP115	-60	V
		TIP116	-80	
		TIP117	-100	
V <sub>CEO</sub>	Collector-emitter voltage	TIP115	-60	V
		TIP116	-80	
		TIP117	-100	
V <sub>EBO</sub>	Emitter-base voltage	Open collector	--5	V
I <sub>C</sub>	Collector current-DC		-2	A
I <sub>CM</sub>	Collector current-Pulse		-4	A
I <sub>B</sub>	Base current-DC		50	mA
P <sub>C</sub>	Collector power dissipation	T <sub>C</sub> =25	50	W
		T <sub>a</sub> =25	2	
T <sub>j</sub>	Junction temperature		150	
T <sub>stg</sub>	Storage temperature		-65~150	

## Silicon PNP Darlington Power Transistors

## TIP115/116/117

## CHARACTERISTICS

T<sub>j</sub>=25 unless otherwise specified

SYMBOL	PARAMETER	CONDITIONS	MIN	TYP.	MAX	UNIT
V <sub>CE0(SUS)</sub>	Collector-emitter sustaining voltage	TIP115	I <sub>C</sub> =-30mA, I <sub>B</sub> =0	-60		V
		TIP116		-80		
		TIP117		-100		
V <sub>CEsat</sub>	Collector-emitter saturation voltage	I <sub>C</sub> =-2A, I <sub>B</sub> =-8mA			-2.5	V
V <sub>BE</sub>	Base-emitter on voltage	I <sub>C</sub> =-2A; V <sub>CE</sub> =-4V			-2.8	V
I <sub>CBO</sub>	Collector cut-off current	TIP115	V <sub>CB</sub> =-60V, I <sub>E</sub> =0		-1	mA
		TIP116		V <sub>CB</sub> =-80V, I <sub>E</sub> =0		
		TIP117		V <sub>CB</sub> =-100V, I <sub>E</sub> =0		
I <sub>CEO</sub>	Collector cut-off current	TIP115	V <sub>CE</sub> =-30V, I <sub>B</sub> =0		-2	mA
		TIP116		V <sub>CE</sub> =-40V, I <sub>B</sub> =0		
		TIP117		V <sub>CE</sub> =-50V, I <sub>B</sub> =0		
I <sub>EBO</sub>	Emitter cut-off current	V <sub>EB</sub> =-5V; I <sub>C</sub> =0			-2	mA
h <sub>FE-1</sub>	DC current gain	I <sub>C</sub> =-1A; V <sub>CE</sub> =-4V	1000			
h <sub>FE-2</sub>	DC current gain	I <sub>C</sub> =-2A; V <sub>CE</sub> =-4V	500			
C <sub>ob</sub>	Output capacitance	I <sub>E</sub> =0; V <sub>CB</sub> =-10V, f=0.1MHz			200	pF

PACKAGE OUTLINE

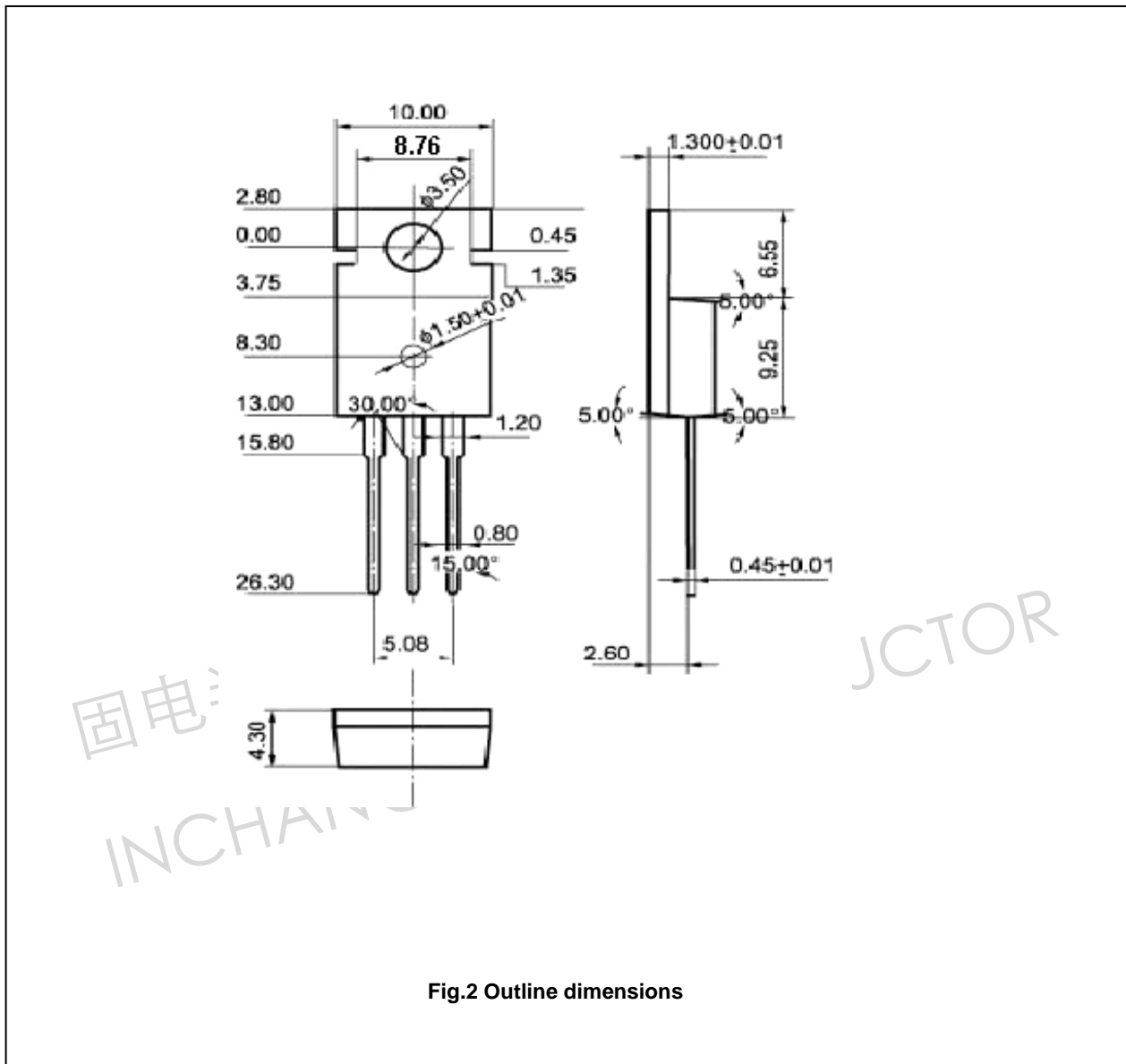

Fig.2 Outline dimensions

Silicon PNP Darlington Power Transistors

TIP115/116/117

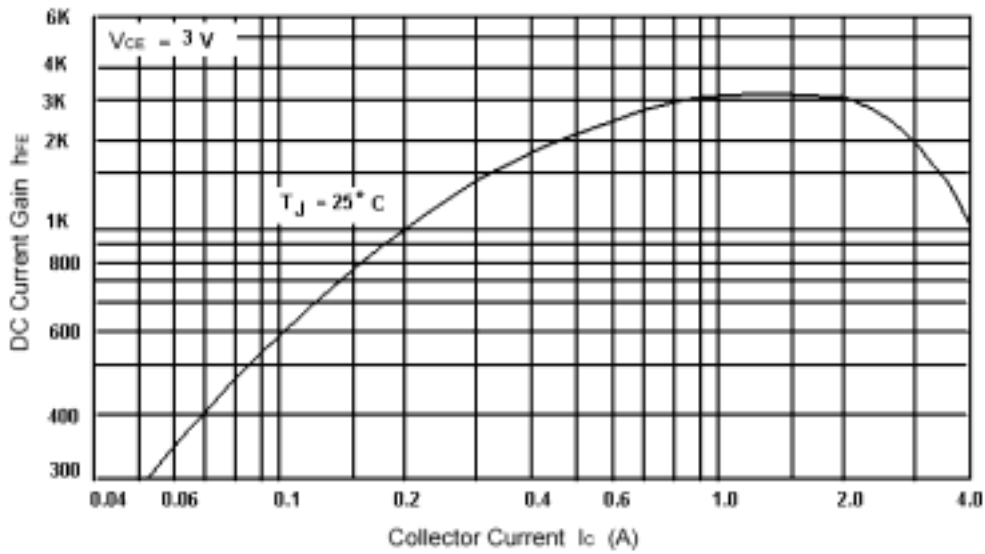

Fig.3 DC current Gain

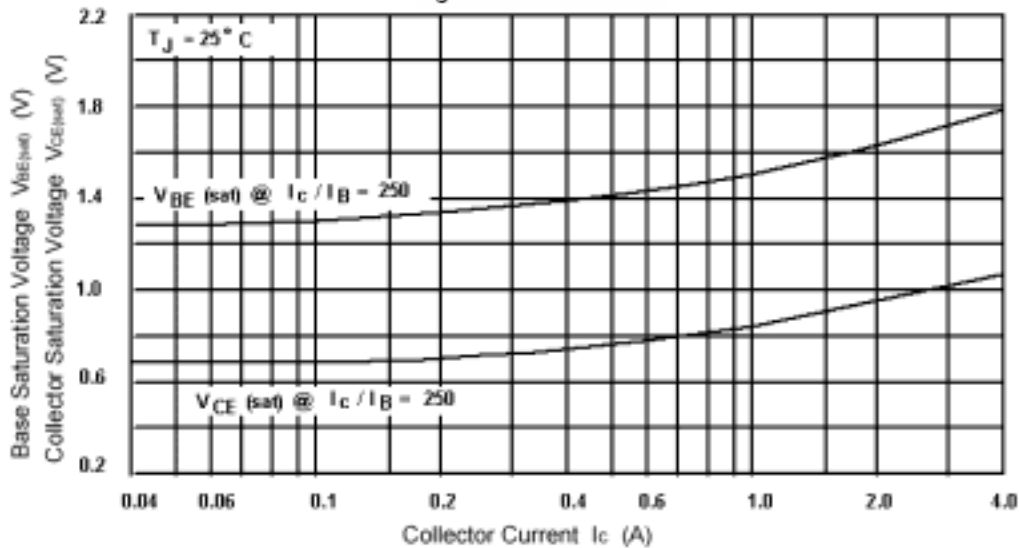

Fig.4 Base-Emitter Saturation Voltage  
Collector-Emitter Saturation Voltage

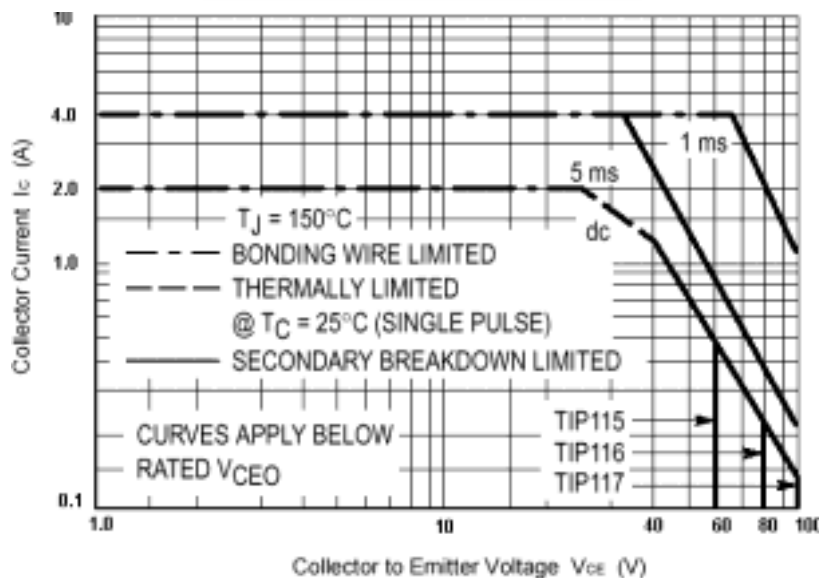

Fig.5 Safe Operating Area